

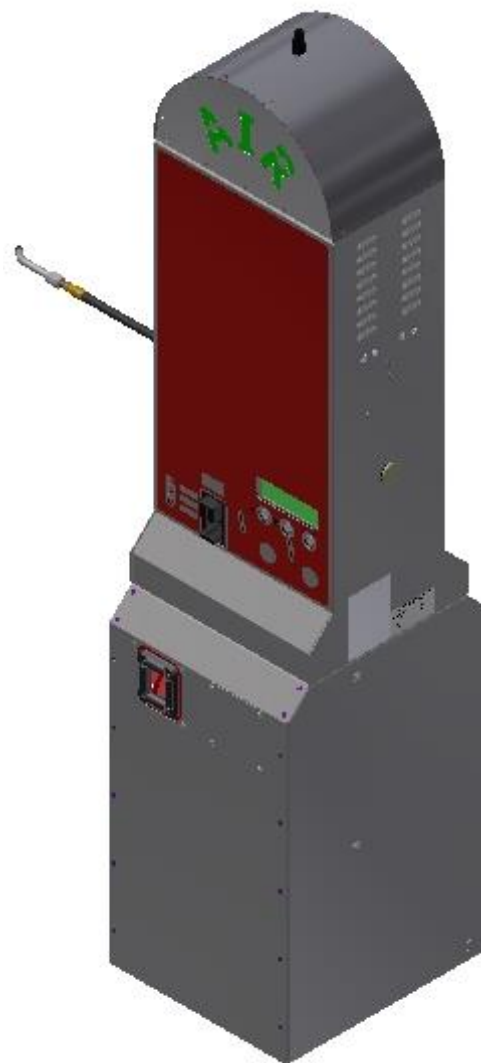

Models – **8799PV, 8799PVW, 8799SV, 8799SVW,
8799PB, 8799PBW, 8799SB, 8799SBW**

Page 2	Product Information
Page 3	Specifications
Page 4	Important Safety Instructions
Page 5-6	Product Dimensions
Page 7-12	Installation “V” Series
Page 13-14	Installation “B” Series
Page 15	Timer Set-Up
Page 16	Coin Box Removal Instructions
Page 17	Operating Instructions & Maintenance
Page 17-18	Troubleshooting
Page 19-21	Protel Specific Troubleshooting
Page 22-28	Parts List
Page 29-30	Wiring Diagram



PRODUCT INFORMATION

Please take a moment to fill out the information below in order to aid us with any future sales or service inquiries. Model number and serial number information can be found on the serial tag located inside the control box and/or on the lower exterior of the can. Key number can be found on the tag that comes attached to the keys. There may be more than one key number depending on unit.

Please keep this information with your records.

MODEL#: _____

SERIAL#: _____

KEY NUMBER(S): _____

DATE PURCHASED: _____

DISTRIBUTOR: _____

**J.E. Adams Industries
1025 63rd Ave. S.W.
Cedar Rapids, IA 52404
1-800-553-8861
www.jeadams.com**

Specifications

<u>Unit specifications:</u>	8799 SERIES
Voltage:	120vac, 60hz
Amperage:	(1) 10 amp service is required
Compressors:	¾ HP, twin cylinder Gast
Water Solenoid:	120vac, 60hz
Timer:	SSAC or ASY400
Weight:	112 LBS, no packaging, 8799 machine only
Unit Labeling:	Air "8799" SSAC timer "S" ASY400 controller "P" Water "W" Base Ground Mount "B" Vault "V"
Locks:	Removable plug lock, 3/8" allen wrench required (provided – SEE FIG A)

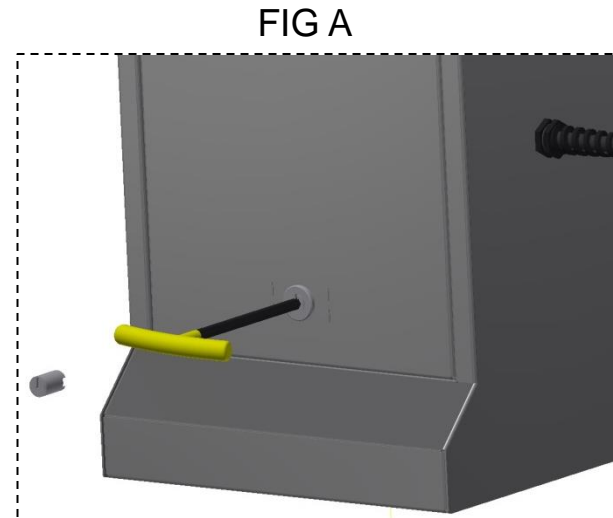

DUTY CYCLE: 4 minutes on, 4 minutes off.

NOTE: "UNIT INTENDED FOR COMMERCIAL USE ONLY"

IMPORTANT SAFETY INSTRUCTIONS

When using an electrical appliance, basic precautions should always be followed, including the following:

READ ALL INSTRUCTIONS BEFORE USING (THIS APPLIANCE)

WARNING – To reduce the risk of fire, electric shock, or injury:

- Use only as described in manual. Use only manufactures recommended attachments.
- Do not allow to be used as a toy. Close attention is necessary when used by or near children.
- Do not put any object into openings. Do not use with any opening blocked; keep free of dirt and anything that may reduce flow.
- Keep hair, loose clothing, fingers, and all parts of body away from openings and moving parts.
- Do not use near flammable or combustible liquids, such as gasoline, or use in areas where they may be present.
- Do not use near anything that is burning or smoking, such as cigarettes, matches, or hot ashes.
- Products such as "Fix-A-Flat" are highly combustible and cannot be used in conjunction with air machine!



SAVE THESE INSTRUCTIONS



- **Installation Instructions:**
- Determine location to mount unit (“**DANGER**” “**THIS EQUIPMENT INCORPORATES PARTS SUCH AS SWITCHES, MOTORS, OR THE LIKE THAT TEND TO PRODUCE ARCS OR SPARKS THAT CAN CAUSE AN EXPLOSION. WHEN LOCATED IN GASOLINE-DISPENSING AND SERVICE STATIONS INSTALL AND USE AT LEAST 20 FEET (6 M) HORIZONTALLY FROM THE EXTERIOR ENCLOSURE OF ANY DISPENSING PUMP AND AT LEAST 18 INCHES (450 MM) ABOVE A DRIVEWAY OR GROUND LEVEL.**”
- Run electrical service to that location.
- **Grounding Instructions:** This appliance must be connected to a grounded metal, permanent wiring system; or an equipment-grounding conductor must be run with the circuit conductors and connected to the equipment-grounding terminal or lead on the appliance.
- All local and national electric codes must be followed for installation and use.
- Licensed electricians are recommended for installation.

PRODUCT DIMENSIONS

8799 SERIES "B"

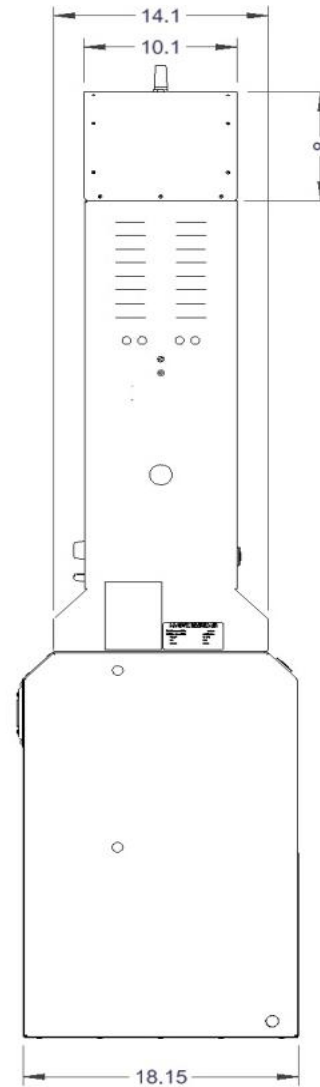
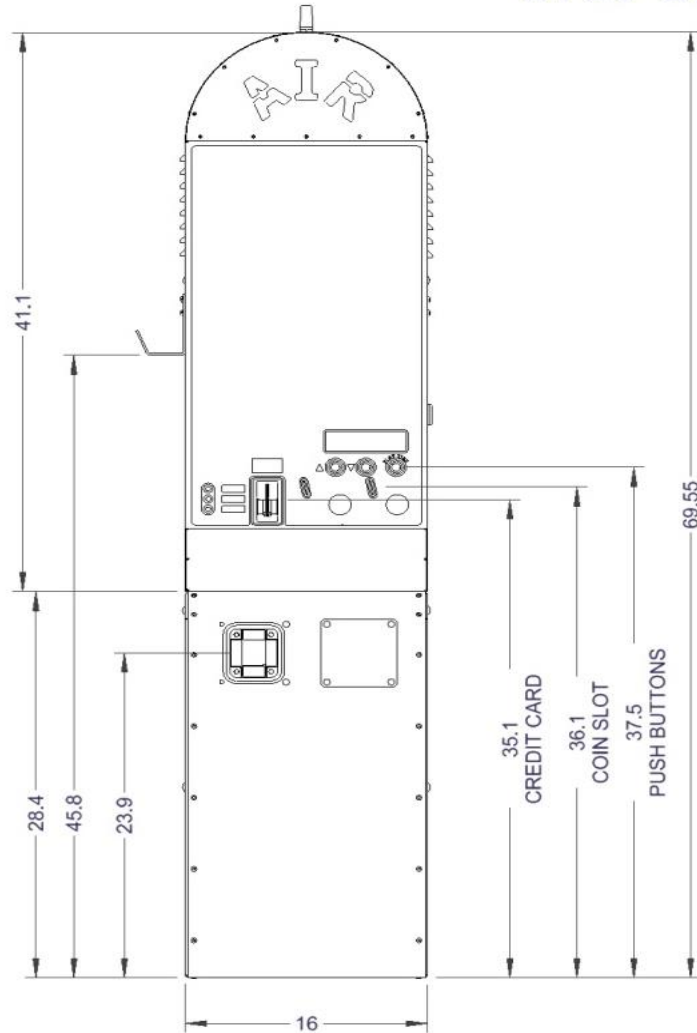

PRODUCT DIMENSIONS

8799 SERIES "V"

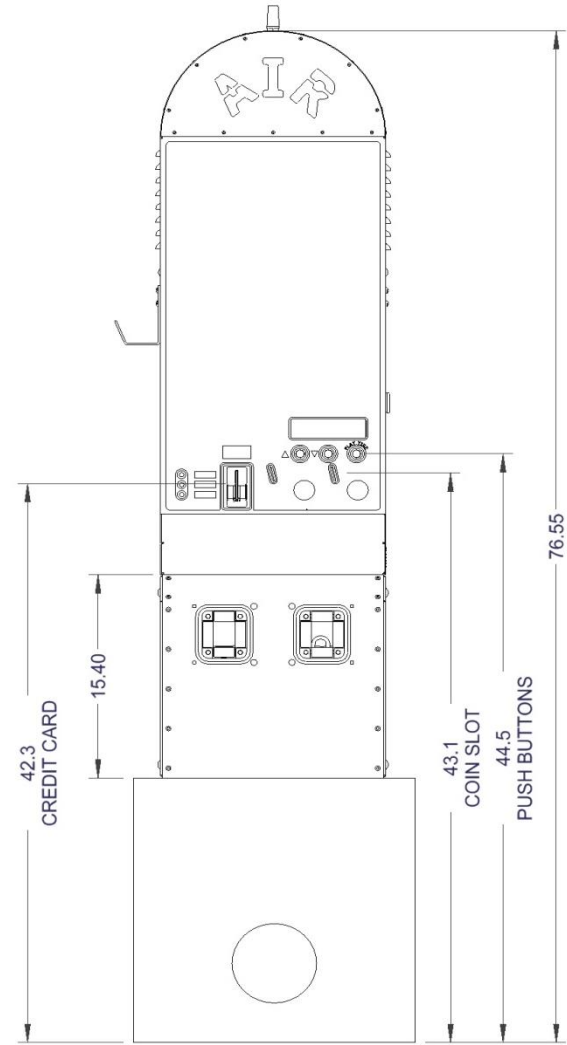
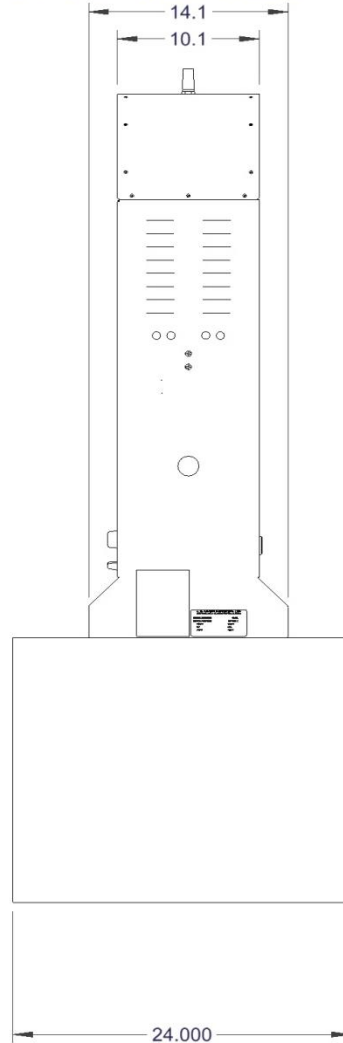
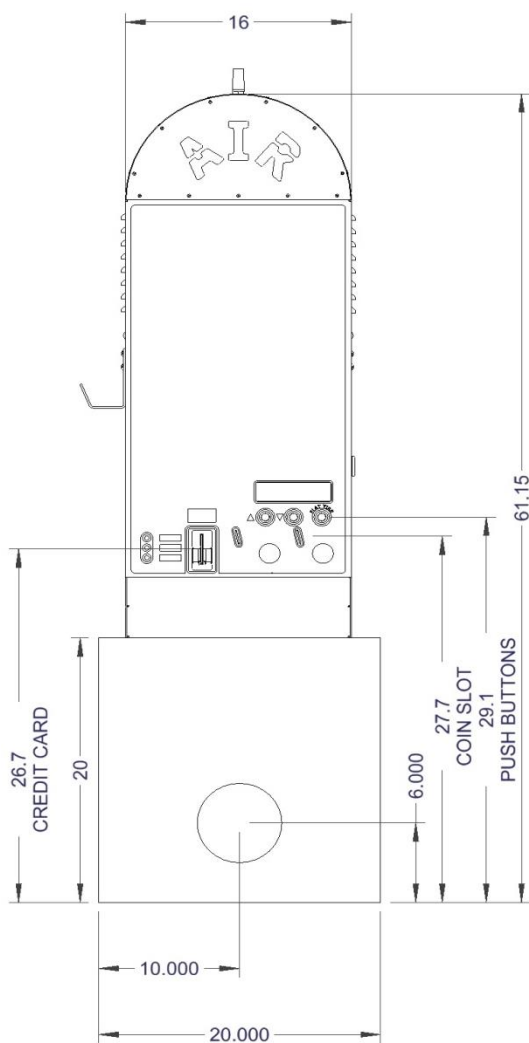

8685-4000A Vault Form (For "V" Series Units Only)

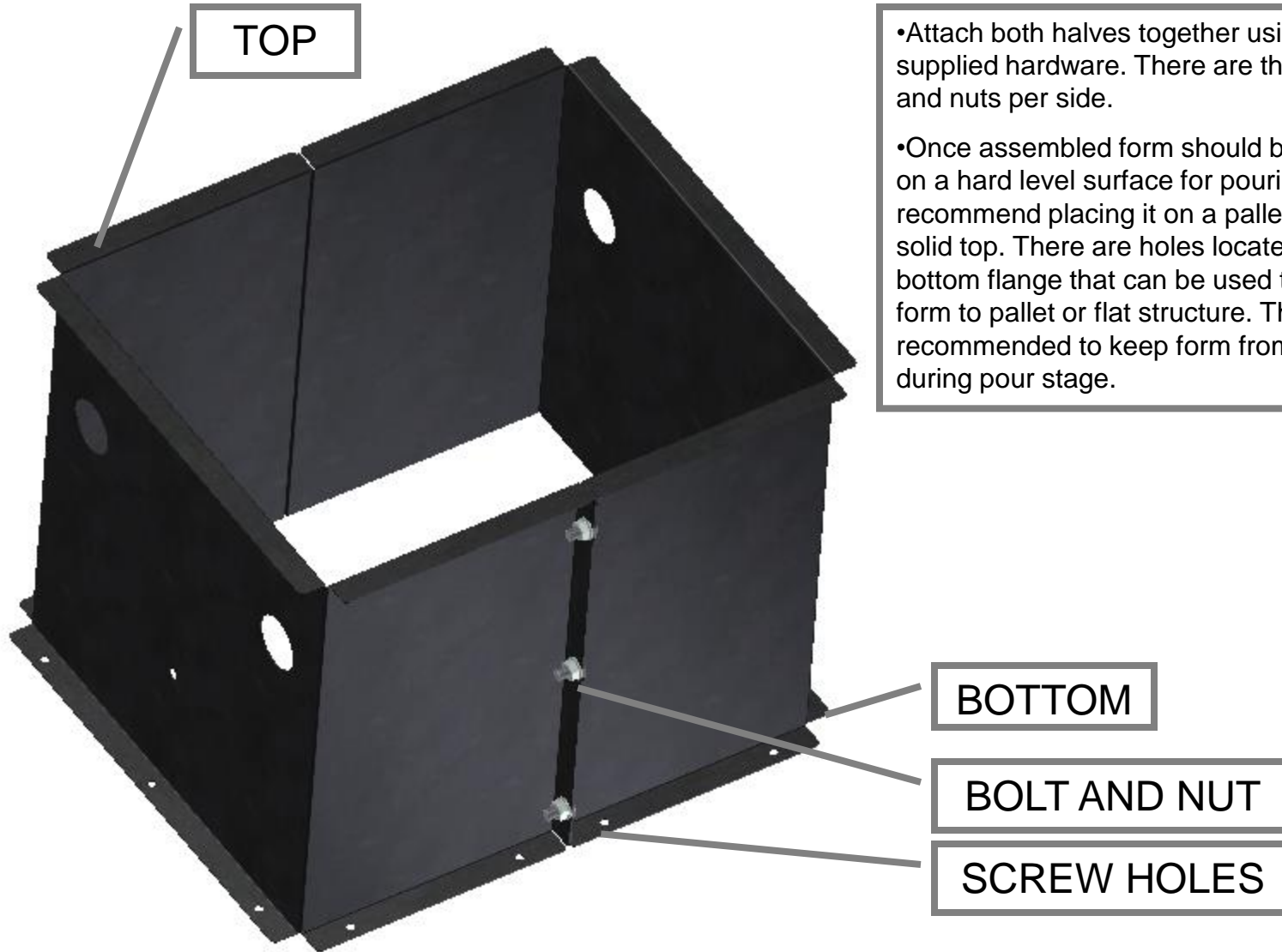

- Attach both halves together using supplied hardware. There are three bolts and nuts per side.

- Once assembled form should be placed on a hard level surface for pouring. It is recommend placing it on a pallet with a solid top. There are holes located on the bottom flange that can be used to screw form to pallet or flat structure. This is recommended to keep form from moving during pour stage.

BOTTOM

BOLT AND NUT

SCREW HOLES

8685-4000A Vault Form (For "V" Series Units Only)

•Insert plug into hole on front side of form and attach wing nut. Do not tighten wing nut down completely at this point.

FRONT

PLUG

BACK

8685-4000A Vault Form (For "V" Series Units Only)

- Insert vault assembly into form.
- Place opening of vault over plug and press until it mates with form and tighten wing nut on front of form until the vault assembly is sealed and no movement is allowed.

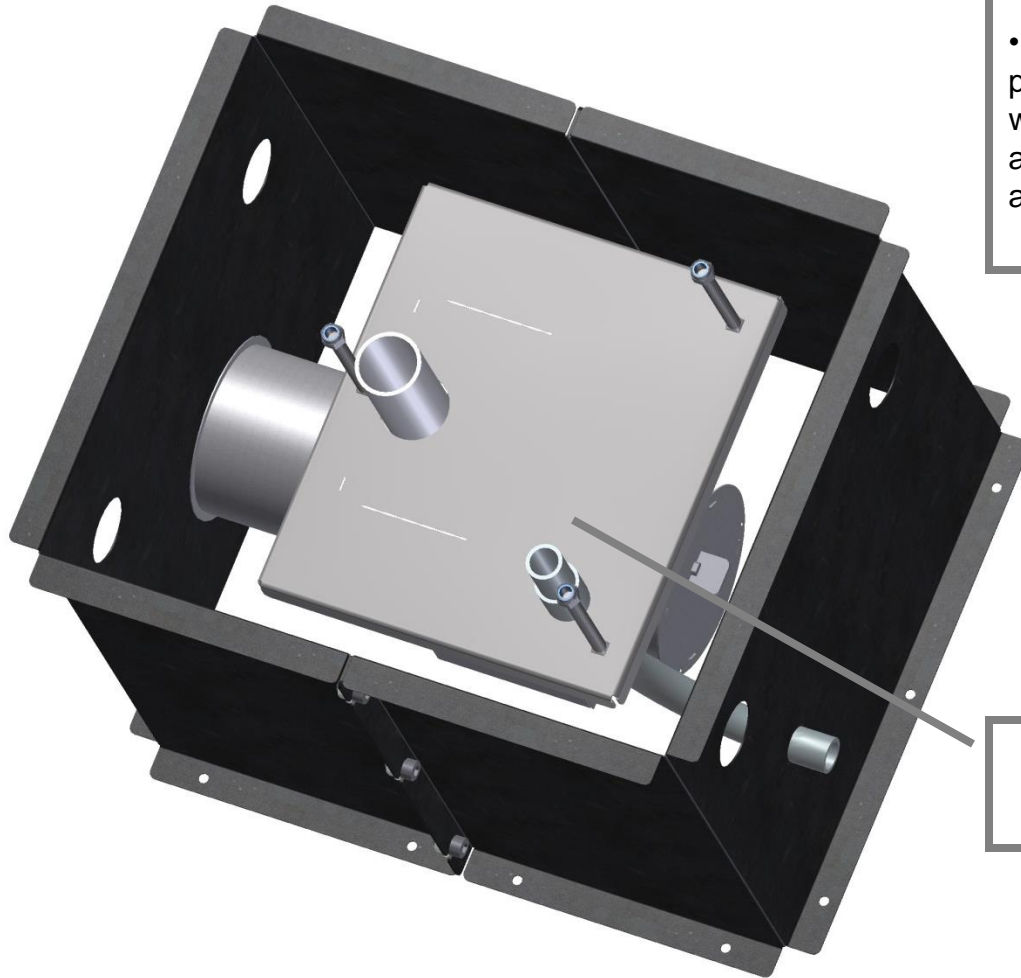

8799-999A VAULT
ASSEMBLY

8685-4000A Vault Form (For "V" Series Units Only)

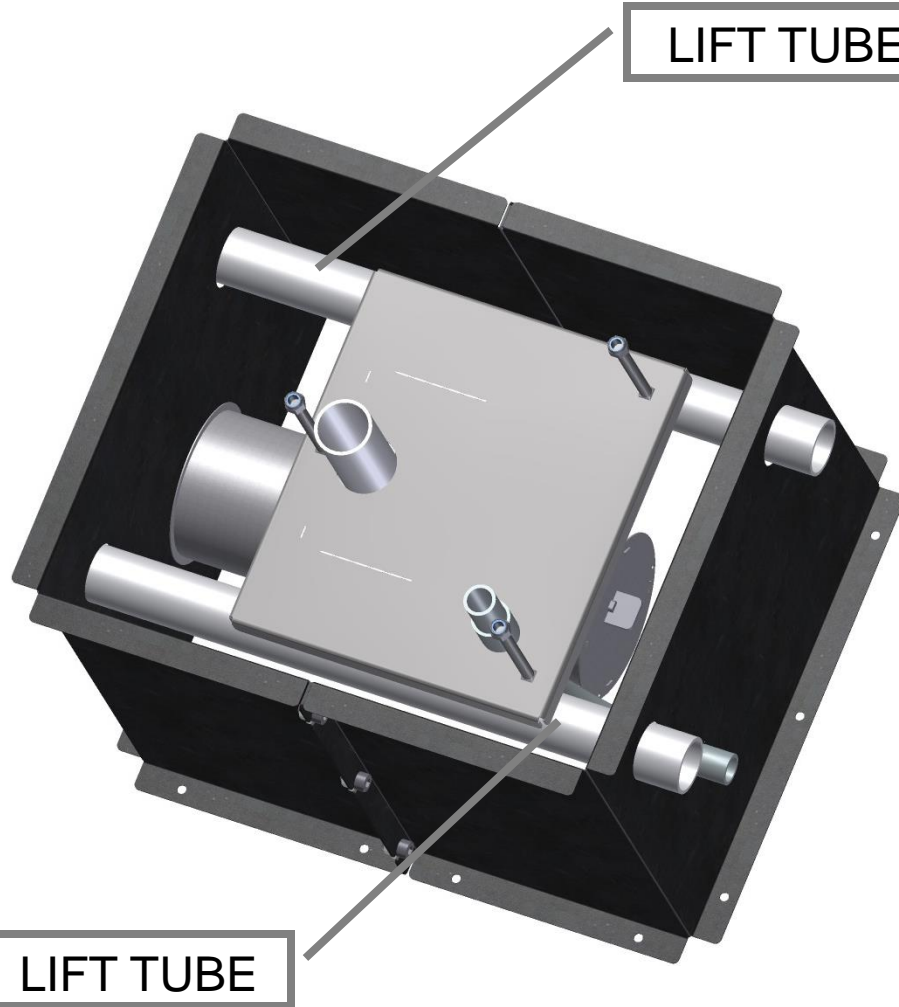

- Insert lift tubes into holes in form. Make sure there is approximately 2" sticking out each end.

- At this point it is recommended to coat the inside of the form with a light coat of oil. This will aid in keeping the form from sticking to the concrete and allow it to be removed easier.

- Form is now ready for concrete. It is recommend using highway grade mix for best results

- Pour in concrete and make sure to fill all the crevices with mix. A concrete vibrate may also be used to make sure the mix spreads evenly. Do not over vibrate or concrete may become too thin.

- Wait 24-48 hours to dry. When dry remove screws from deck and remove bolts from form. Loosen wing nut on front and slide panels off concrete block. Save forms for another pour.

8685-4000A Vault Form (For "V" Series Units Only)

WIRE FROM ELECTRICAL BOX SHOULD COME OUT HERE. MAKE SURE THERE IS ENOUGH WIRE TO REACH MACHINE INCOMING POWER TERMINALS

- Once form is removed the block should look like this.
- Cut excess material from lift tubes to be flush with concrete. (4PL)
- Open up vault door and clean out any water or concrete residue from the inside of vault.
- Attach electrical box on back of concrete block.

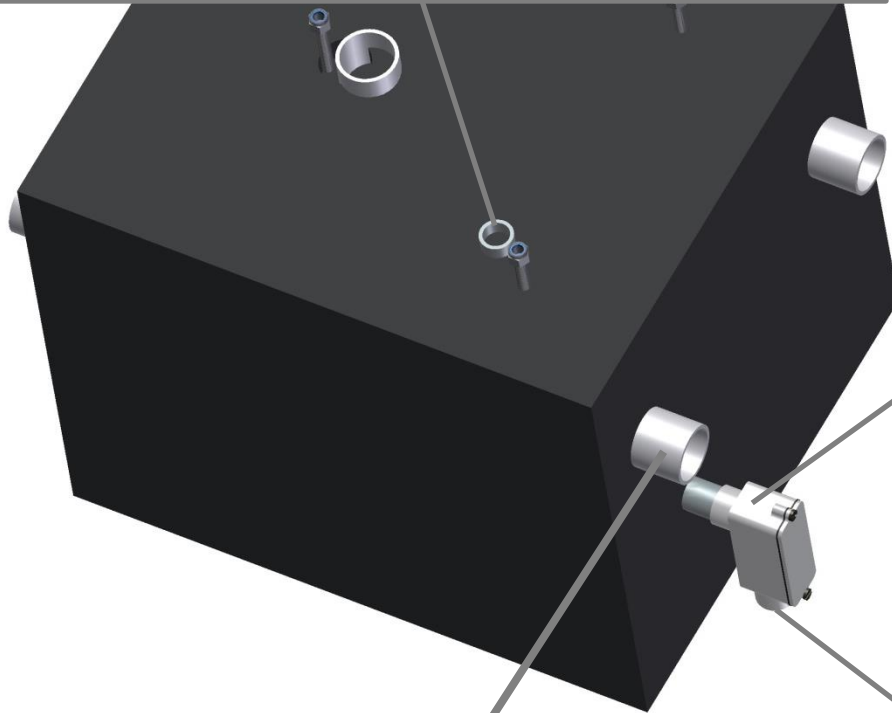

ELECTRICAL BOX

CUT LIFT TUBE FLUSH WITH BLOCK

INCOMING ELECTRICAL TO HERE

8685-4000A Vault Form (For "V" Series Units Only)

- Mount unit on concrete using the studs coming out of the concrete. Attach using nuts provided.

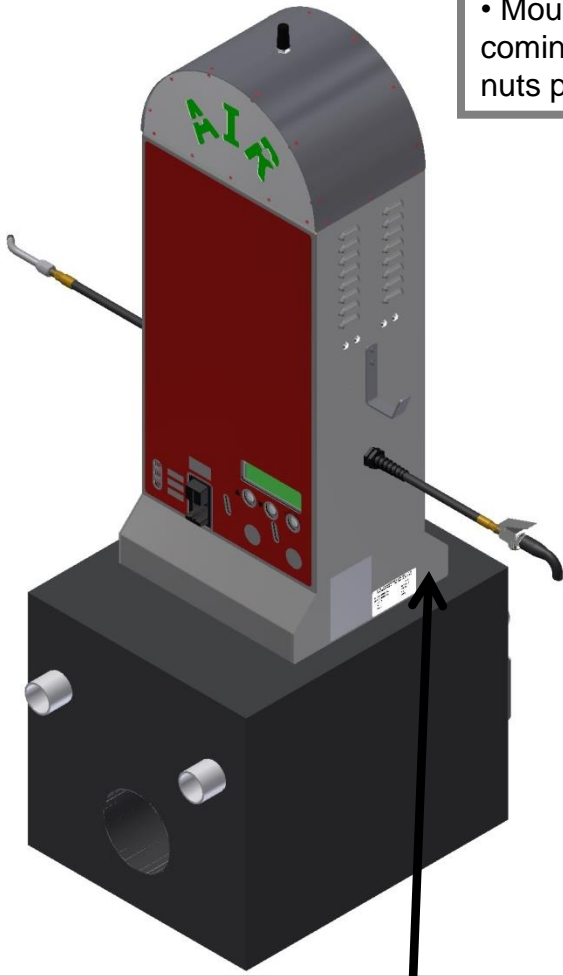

- If unit has water push out knockout in right lower side of unit and plumb water thru and into solenoid inside machine.

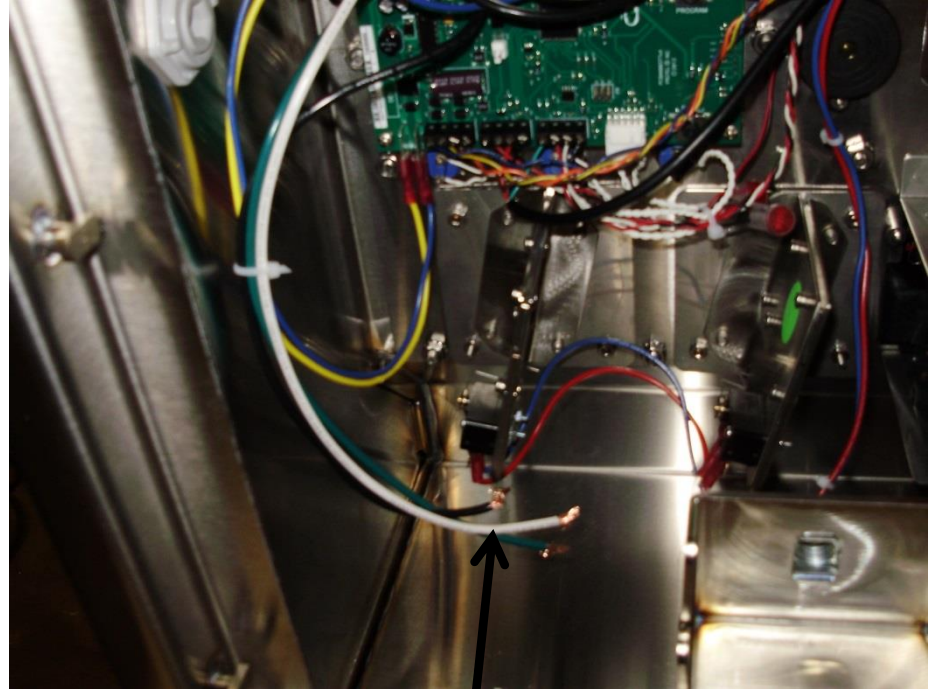

- Attach incoming wire to machine using the black, white and green pigtail as shown.

Installation for "B" series unit

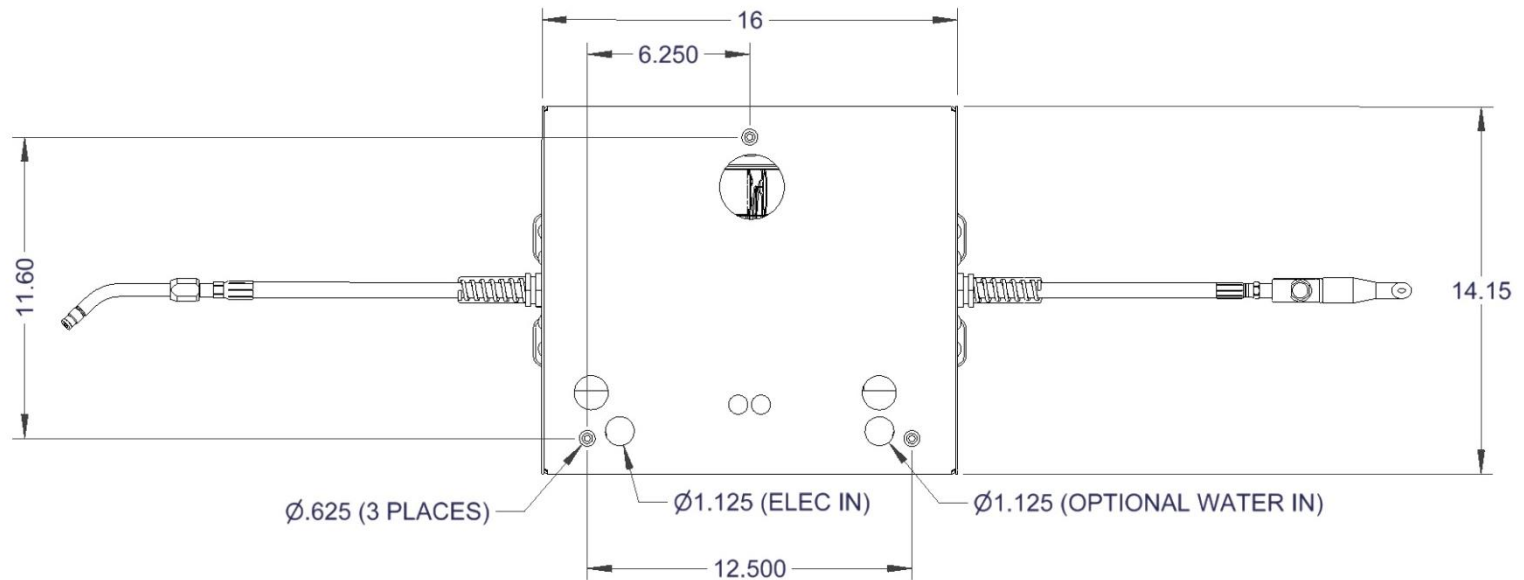

- Above drawings shows the mount pattern for the base mount unit. The single hole is the front machine.
- Determine your machine location and mark spots accordingly.
- It is recommended that 3/8" anchors be used to secure machine in place.

Installation for "B" series unit



- If unit has water push out knockout in right lower side of unit and plumb water thru and into solenoid inside machine.
- Water can also be ran up from bottom of unit. See previous page for location.

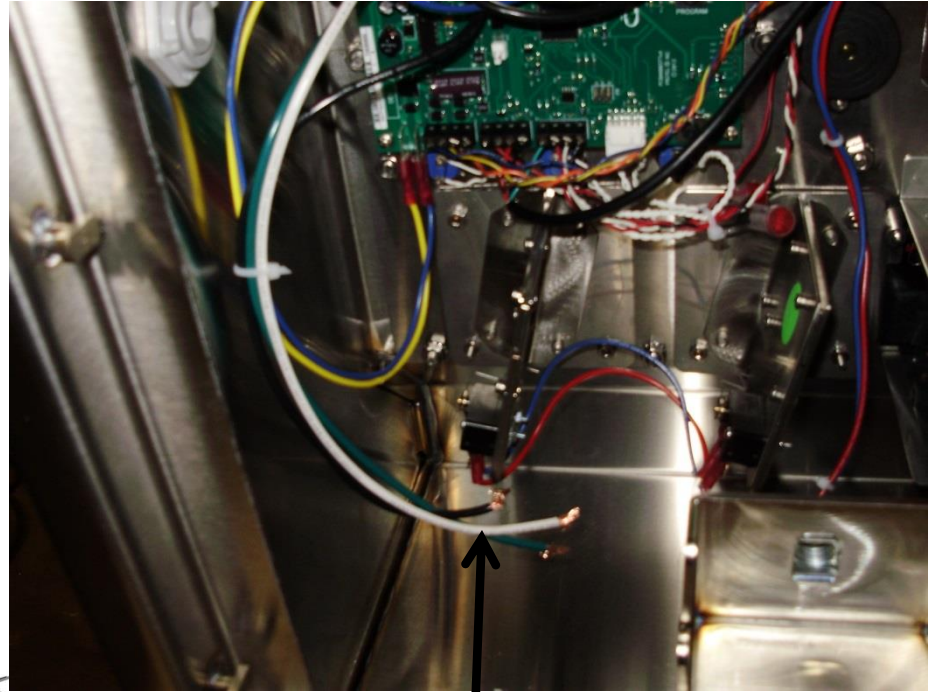

- As shown on previous page electrical is to be plumbed thru bottom of unit.
- After machine is mounted and wire ran into cabinet attach incoming wire to machine using the black, white and green pigtail as shown.

Programing for Protel Controller: Contact Protel for activation and controller information. There is a decal inside machine with contact number.

Programming:

The below timer pictured is the standard SSAC model that allows the end user to select the "coins to start" and the "time per coin" by settings series of dip switches. The number of "coins to start" dip switch is how many quarters are needed to make the machine come on. In the below example, the "one coin" dip is selected which makes the unit come on with one coin. The "time per coins" will then need to be set, but a good rule of thumb would be 4 minutes which requires dip switches 3.2 and .8 to be set to on. This scenario means 1 quarter will provide 4 minutes of vacuum time. The time per coin setting can be modified as desired by simply adding or subtracting time. If the operator would later decide to increase the cost of the unit to "2" quarters, the 2 dip switch would need to be in the on position (all other off) and the time dip switches would need to have the 1.6 and 0.4 dips selected. This would allow 2 minutes of time for each quarter for a total of 4 minutes for two quarters.

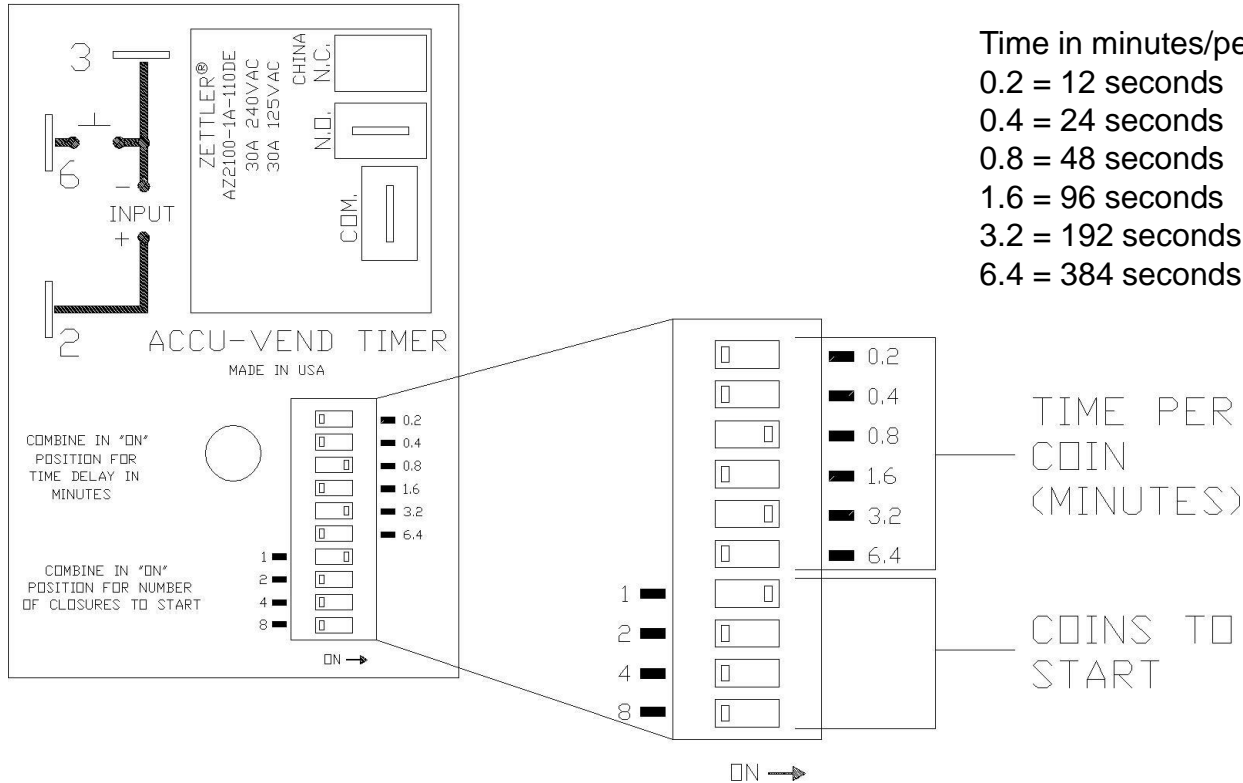

Time in minutes/per coin dip switch settings:

- 0.2 = 12 seconds
- 0.4 = 24 seconds
- 0.8 = 48 seconds
- 1.6 = 96 seconds
- 3.2 = 192 seconds
- 6.4 = 384 seconds

TIME PER COIN (MINUTES)

COINS TO START

Coin Box Removal

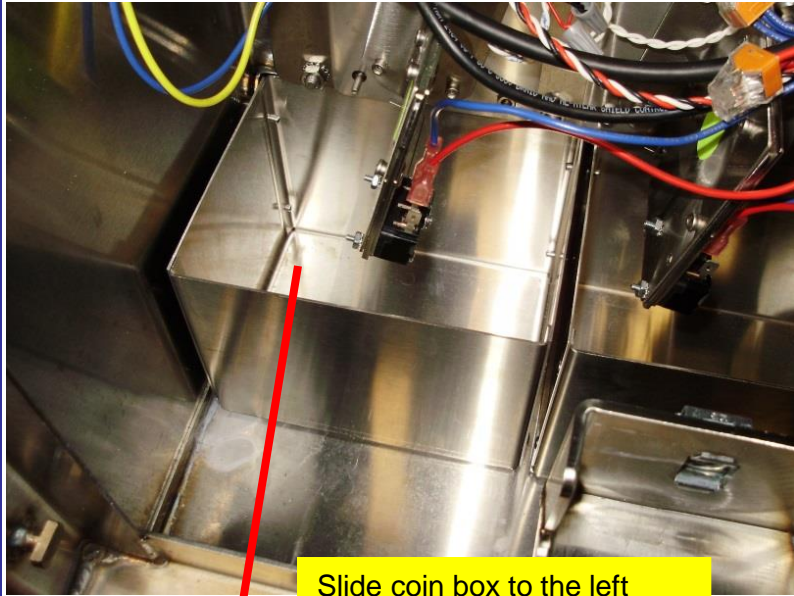

Slide coin box to the left back side of unit.

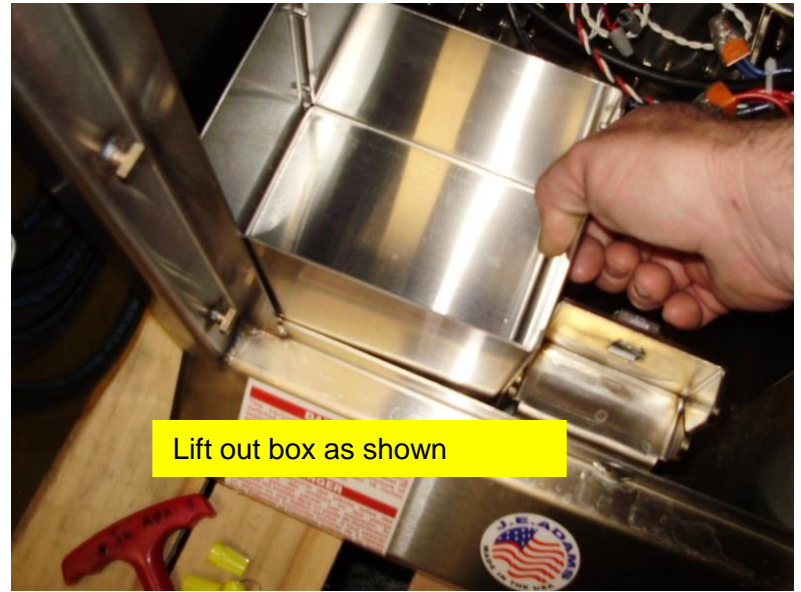
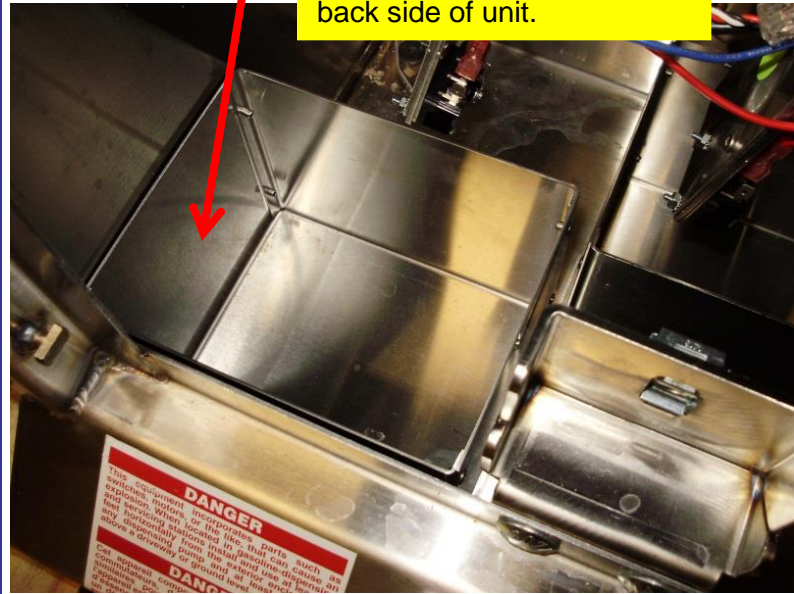

Lift out box as shown

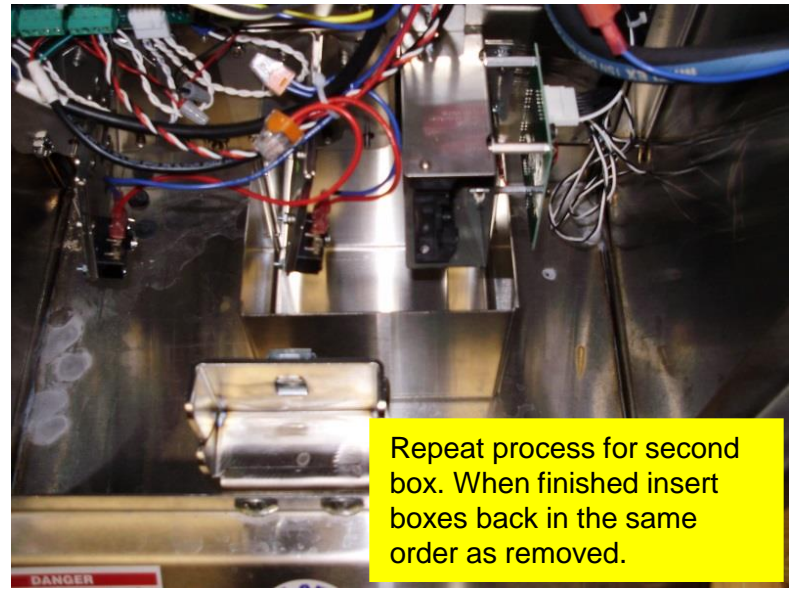

Repeat process for second box. When finished insert boxes back in the same order as removed.

Machine Operating Instructions:

- 1) Read safety instructions on previous pages.
- 2) Insert coins (or bills) to start.
- 4) Use increase or decrease buttons select desired pressure.
- 5) Apply chuck to tire valve stem and fill to desired pressure. NOTE: For best results, remove valve stem covers on all tires before depositing money.
- 6) Hang hose up when finished.

Maintenance:

- **All servicing of machine should be conducted by an authorized service representative!**
- Periodically inspect hose, chuck, and chuck washer for wear or fatigue.
- Every month remove filter from compressor and clean.
- Periodically inspect electrical wires and connections for wear or fatigue.
- Clean canister with a stainless steel cleaner as needed.
- Decals can be cleaned with mild soap and water.
- Replacement parts can be ordered through JE Adams or your nearest dealer.

WHEN PERFORMING MAINTENANCE OR TROUBLE-SHOOTING, TURN POWER OFF! QUALIFIED PERSONNEL ONLY!



TROUBLESHOOTING:

ALWAYS DISCONNECT POWER BEFORE TROUBLESHOOTING!!

Problem	Possible cause	Solution
Unit is not powered.	Breaker inside fuse panel is not in the on position.	Turn breaker on.
	No power to machine.	Check incoming power line voltage.
	Machine power switch is not on.	Remove dome and flip switch.
	Loose connection.	Check incoming power connection.

Unit runs but will not inflate tire.	Air is leaking from unit somewhere.	Turn power off to unit, apply chuck to air source with at least 30lbs of pressure and listen carefully for leaks inside cabinet or air hose. Replace faulty component if leaking.
	If no system leaks, is compressor putting out enough pressure?	If compressor cannot force air into tire, the compressor may have exceeded its life span and need rebuilt (about 1000 hours).
	Temperature is below freezing and condensation off compressor has froze in air hose.	Remove air hose and chuck and bring into warm area to thaw. Optional air dry systems are available through JE Adams if frequent problem- please call.
Unit keeps tripping breaker from incoming power source	Wrong size breaker or other components running on same circuit.	Install correct breaker for compressor and make sure line is a dedicated power source.
	Compressor or timer might be shorted out?	Isolate problem component and replace if necessary.
Unit will not start	Possible component failure	Check key components to isolate failure: Timer: Verify proper input voltage. Activate timer. If no output voltage is present when timer should be active, replace timer.
		Coin mech: If using a mechanical coin mech, remove the wires leading to the timer from the coin mech and tap the together one time for each coin necessary to start the timer. If machine starts, replace the coin mech.
Unit will not dispense water (water machines only).	Is source water turned on and not frozen?	Turn on water to system and make sure temperature is above 32 deg.
	Is water solenoid getting power from timer?	If getting power from timer, replace solenoid.

Caution! -lethal voltage is present in all compressed air vending machines. Repair should only be attempted by trained technicians. Note -Tests should be performed in order for proper diagnosis.

1.00 Check for loose connections:

Loose or broken wires can cause misleading symptoms. Check all connections before proceeding.

2.00 Check AC power:

The pressure regulator circuit board and solenoids operate from a 24VAC power transformer. The LCD display should have white LED back-lighting and the unit should indicate a 32 psi set point and 0 psi during idle mode. If the display fails this check, the board is most likely not receiving 24VAC power. If power is present at the 0.250" tab terminals, replace the digital pressure board and/or display.

3.00 Adjust set point :

Adjust the set point with the up and down buttons. The buzzer should beep with every adjustment.

3.01 Potential faults if set point does not increment or decrement:

Loose or broken push button wires
Push button
Digital pressure board

3.02 Potential faults if the buzzer does not beep:

Loose or broken buzzer wiring
Buzzer
Digital pressure board

4.00 Read tire pressure :

With the compressor off, attach the air chuck to a tire. The display should indicate the tire pressure. The buzzer should beep when stable pressure is detected. Note the pressure and remove the chuck. Measure the tire with an accurate hand-held tire gauge. Compare the two readings.

Note -stick gauges are notoriously inaccurate, use a quality instrument for this procedure. Make sure a good seal is achieved for each measurement. Any air escaping during this procedure will greatly affect accuracy. The test tire should be at 32 to 50 psi for best results.

4.01 Potential faults if pressure is not within a few psi of measured tire pressure:

Tire chuck
Leaks in fittings or hose
Loose or broken pressure sensor cable
Solenoid stuck open
Pressure sensor

Digital pressure board:

4.02 Potential faults if pressure is within a few psi of measure tire pressure:

Digital pressure board requires calibration
Faults listed under 4.01

5.00 Calibration :

Skip this step if tire accuracy is within acceptable limits.

Tools:

Michelin MN-12279 Tire Gauge recommended (displays pressure to 0.1 PSI resolution).

Notes:

Make sure the compressor is off before entering the calibration mode and remains off during the entire calibration process.

5.01 Press and hold the "PROGRAM" button on the digital pressure circuit board. After approximately 2 seconds, the buzzer will beep and "CAL" will be displayed. Release the button. The exhaust solenoid will be enabled for 2 seconds after which all of the display segments will be turned on to allow for visual inspection of the display. After an additional 3 seconds, the exhaust solenoid will be disabled and the display will show the pressure in 0.1 psi increments (example "P 0.3").

Note -during the time that all display segments are enabled, the pressure board is adjusting the pressure sensor input for 0 psi measurements. The pressure displayed initially will include any previously calculated offset.

5.02 Attach the air chuck to the tire until the unit starts beeping, indicating that the pressure reading is stable. Remove the air chuck from the tire (the captured pressure reading will continue to be displayed until the chuck is attached to the tire again). Measure the tire pressure with the Michelin tire gauge and press the up or down button so that the pressure displayed matches the pressure measured with the Michelin tire gauge. Note -Make sure a good seal is achieved for each measurement. Any air escaping during this procedure will greatly affect accuracy. The test tire should be at 32 to 50 psi for best results.

5.03 **The calibration mode can be exited in one of three ways:**
1) Pressing the PROGRAM button for less than 2 seconds will exit the calibration mode without saving the new calibration values.
2) Holding the PROGRAM button for 2 seconds until the beeper starts beeping rapidly will save the new calibration values.
3) The pressure board will automatically exit calibration mode if no button is pressed or no change in pressure reading is detected for 60 seconds and the new calibration values will not be saved.

Tire inflation/deflation

6.01 Deposit the required number of quarters to activate the compressor. Adjust the set point to the desired tire pressure. Attach the tire chuck to the tire and verify a good seal is achieved. The digital pressure board should detect the tire and begin the process unless it is flat. Depressing the flat tire button will dispense air until the tire is detected. The buzzer should beep several times when the tire pressure matches the set point.

6.02 **Potential faults during inflation/deflation test:**
Loose or broken solenoid wires
Current sensor cable
Leaks between compressor and manifold
Foreign debris in solenoid seal area
Solenoid
Weak compressor
Faulty over-pressure relief valve
Digital pressure board

PART NO
8799PB

BILL OF MATERIALS			
ITEM	PART NUMBER	DESCRIPTION	QTY
30	8799-27W	LOCK HOUSING WELDMNT	1
31	8799-40A	DOME ASSEMBLY	1
32	8799-5	COMPRESSOR BRACKET	2
33	8799-500W	CONTROL CABINET WELDMNT- 8799 SERIES W/CC	1
34	8799-502A	CONTROL PLATE ASSEMBLY, PROTEL CONTROLLER	1
35	8799-515AB	BASE, STANDALONE DIGI AIR MOUNT	1
36	8799-6003	PLUG, WATERTIGHT FITTING HP SERIES 2	1
37	8799-6005A	COIN BOX ASSEMBLY	2
38	8799-9A	DIGITAL AIR MANIFOLD ASSEMBLY	1
39	8799-INFO-DECAL	DECAL, PROTEL AND JE ADAMS CONTACT INFO	1
40	8799D-KIT	DECAL KIT, 8799 SERIES FACEPLATE	1
41	9862	COMPRESSOR, 3/4 HP TWIN CYL	1
42	B5722-002	NUT, 3/8-16 UNC HEX LOCK NUT	3
43	B9900-001	WASHER, BONDED SEALER	4
E 45	7722S	1/4" NPT SST HEX NIPPLE MALE	1
E 46	5815D4	ELBOW, FEMALE, 1/4 NPT	1

BILL OF MATERIALS			
ITEM	PART NUMBER	DESCRIPTION	QTY
1	1079-3	GASKET	13.7"
2	22001-6A	PLUG LOCK, LARGE, WITH LOCK CORE	1
3	28000-53	NONMETALLIC TUBE FITTING	1
4	29000-ALLEN	3/8 ALLEN, 29000 PLUG LOCK SCREW	1
5	5600D4	3/8-16 X 1.5 HHCS	3
6	5603D3	3/8 Std NC Nylock Nut	2
7	5606D22	WASHER, 3/8 FENDER	6
8	5619D3	1/2" - 13 HEX SOC HEAD SCREW	1
9	5631d1	1/4-20 SCREW, ONE-WAY HEAD	4
10	5632D5	3/8-16 UNC CARRIAGE BOLT	2
11	5635D4	BOLT, CARRIAGE, 1/4-20 UNC	8
12	5800D6	90 DEG. NPT STREET ELBOW	1
14	8036	NUT, 1/4-20 UNC KEPS	33
15	8047	60" x 70" BAG	1
16	8081	CABLE TIE MOUNTS	5
17	8084	CABLE TIES	20
18	8157	NUT, #6-32 KEPP NUT STAINLESS	2
19	8183	DECAL, "DISCONNECT POWER"	2
20	8437D002	ETL DECAL, AIR MACHINES	1
21	8532-25	AIR HOSE ASSY, 1/4" X 25'	1
22	8533-13	OPEN FLOW CHUCK	1
23	8545-13	AIR HOSE ASSY, 1/4" X 15"	1
24	8549	FLEX STRAIN RELIEF	1
25	8605	PALLET, VAC, 26" X 30.5"	1
26	8678	HOSE HANGER	1
27	8732	NAMEPLATE SERIAL TAG, UL	1
28	8754	DECAL, DANGER, TRI-LING	1
29	8799-25W	ENTRY DOOR WELDMNT	1

NOTE 1

8799-515AB IS TO BE PACKAGE AND SENT ALONG WITH MACHINE, UNLESS OPTION FOR HOSE REEL IS ADDED. (SEE BELOW)

NOTE 2

29000-ALLEN, T HANDLE ALLEN WRENCH USED TO REMOVE ALLEN BOLTS FROM LOCKS. SUPPLIED OPTIONAL:
* 8799-515ABA, HOSE REEL ASSEMBLY. IF PURCHASING REMOVE 8799-515AB (1), 8532-25 (1), 8549 (1) AND 8678 (1) FROM PURCHASE ORDER.

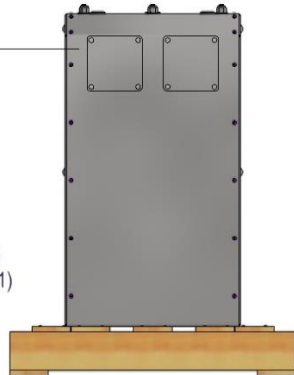

E	8306	REMOVED 5827D1 AND ADDED 5815D4 AND 7722S	8/7/2018	CAK
D	7898	ADDED A MODEL VIEW OF 8799-515AB BASE TO DRAWING AS REF	11-23-16	CK
C	7761	ADDED 29000-ALLEN AS STANDARD	5-12-16	CK
B	7531	ADDED 8799-INFO-DECAL	7-28-15	CK
A	7471	ADDED (1) 8437D002	5-22-15	CK
REV	NO.	DESCRIPTION	DATE	BY

TITLE		DIGITAL AIR MACHINE, PROTEL CONTROLLER W/CC, BASE	
UNSPECIFIED TOLERANCES	MATERIAL	DRAWN BY	CHAD K.
1 PL ±.030		DATE	8/8/2014
2 PL ±.020		SCALE	
3 PL ±.003		SHEET	1 / 6
ANGLE ± 1°		PART NO	8799PB
		REV	E

THIS DOCUMENT SHALL NOT BE REPRODUCED NOR SHALL THE INFORMATION THEREIN BE USED BY OR DISCLOSED TO OTHERS EXCEPT AS AUTHORIZED BY J.E. ADAMS INDUSTRIES

PART NO.

8799PB

DETAIL A

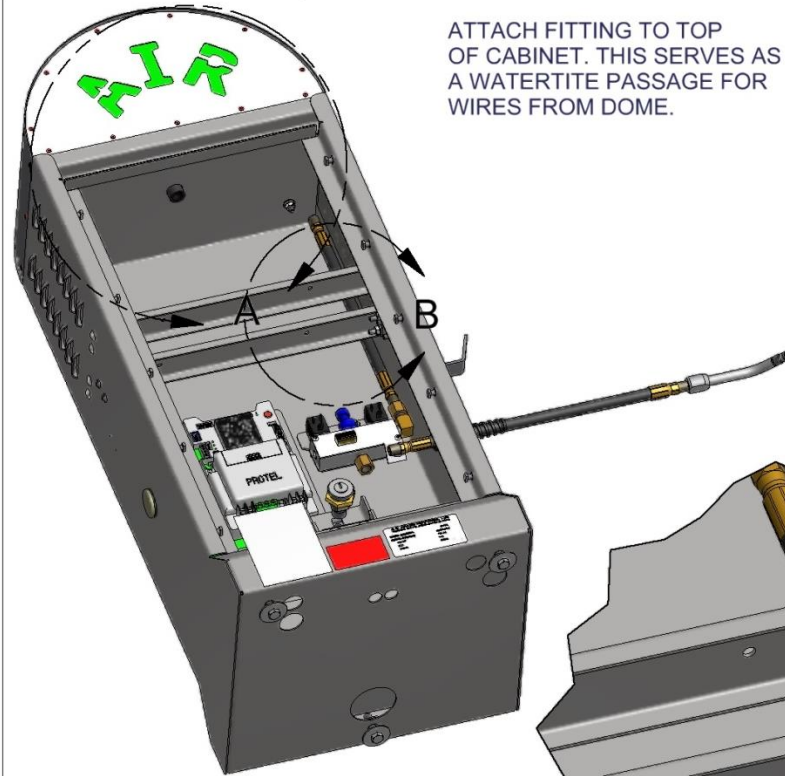

ATTACH FITTING TO TOP OF CABINET. THIS SERVES AS A WATERTITE PASSAGE FOR WIRES FROM DOME.

AIR

29

40 RUN WIRES FROM DOME THRU WATERTITE SEAL JUST INSTALLED. ATTACH DOME ASSEMBLY TO CABINET USING HARDWARE SHOWN. (4PL)

ATTACH COMPRESSOR MOUNT BRACKETS INTO CABINET.

DETAIL B

SHEET 2 OF 6

TITLE		DIGITAL AIR MACHINE, PROTEL CONTROLLER W/CC, BASE	
UNSPECIFIED TOLERANCES	MATERIAL	 CEDAR RAPIDS, IOWA	
1 PL ±.030	SCALE		
2 PL ±.010	DRAWN BY CHAD K.		
3 PL ±.003	DATE 2/2/2015	PART NO. 8799PB	REV.
ANGLE ±1.0°			

REV	NO.	DESCRIPTION	DATE	BY
THIS DOCUMENT SHALL NOT BE REPRODUCED NOR SHALL THE INFORMATION THEREIN BE USED BY OR DISCLOSED TO OTHERS EXCEPT AS AUTHORIZED BY J.E. ADAMS INDUSTRIES				

PART NO. 8799PB

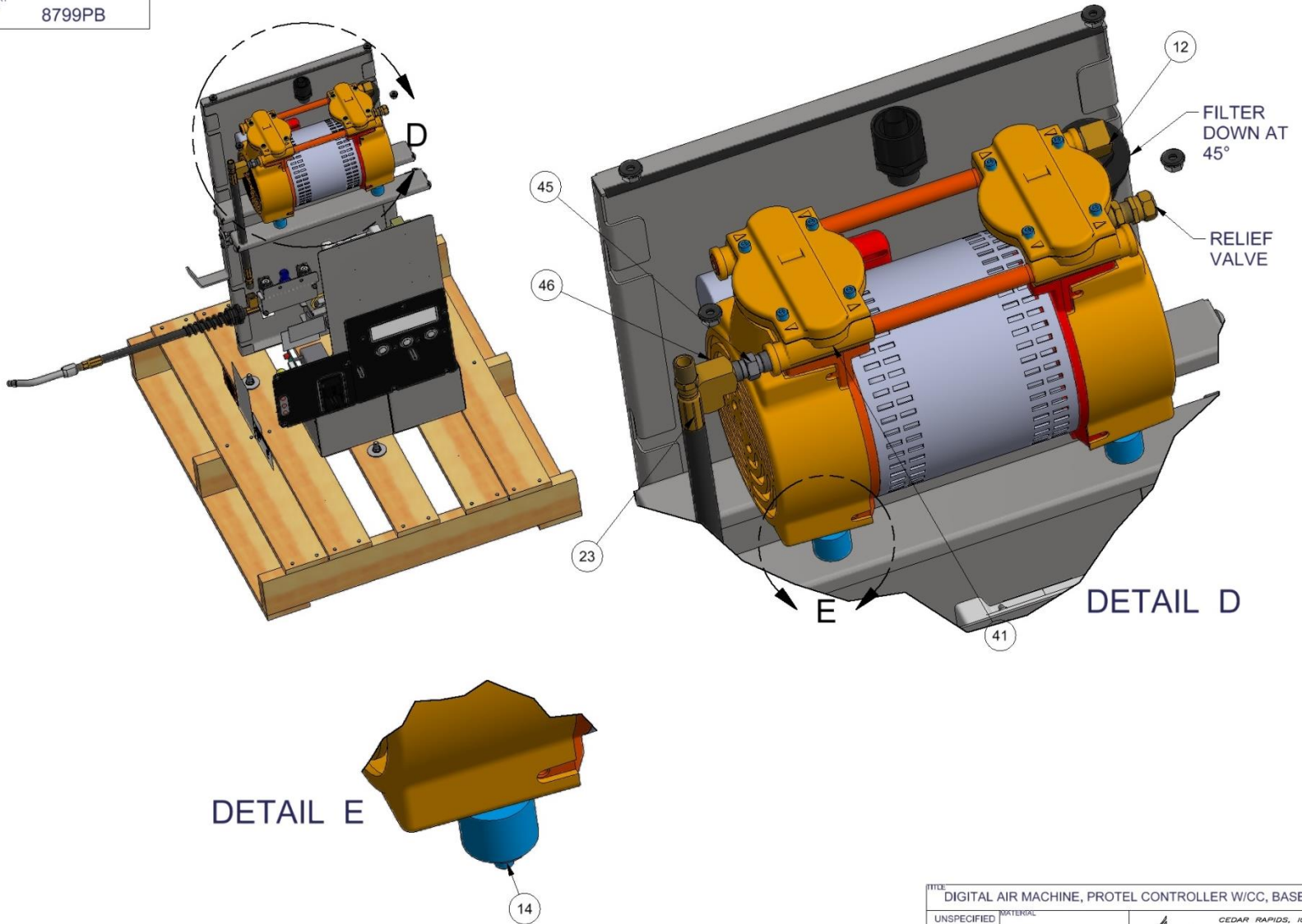

TITLE DIGITAL AIR MACHINE, PROTEL CONTROLLER W/CC, BASE			
UNSPECIFIED TOLERANCES		MATERIAL	
1 PL ±.030	BY CHAD K.	CEDAR RAPIDS, IOWA	
2 PL ±.020	DATE 8/8/2014		
3 PL ±.003	SCALE		
ANGLE ±1°	SHEET 3 / 6	PART NO. 8799PB	REV. E

REV	NO.	DESCRIPTION	DATE	BY
THIS DOCUMENT SHALL NOT BE REPRODUCED NOR SHALL THE INFORMATION THEREIN BE USED BY OR DISCLOSED TO OTHERS EXCEPT AS AUTHORIZED BY J.E. ADAMS INDUSTRIES				

DETAIL F

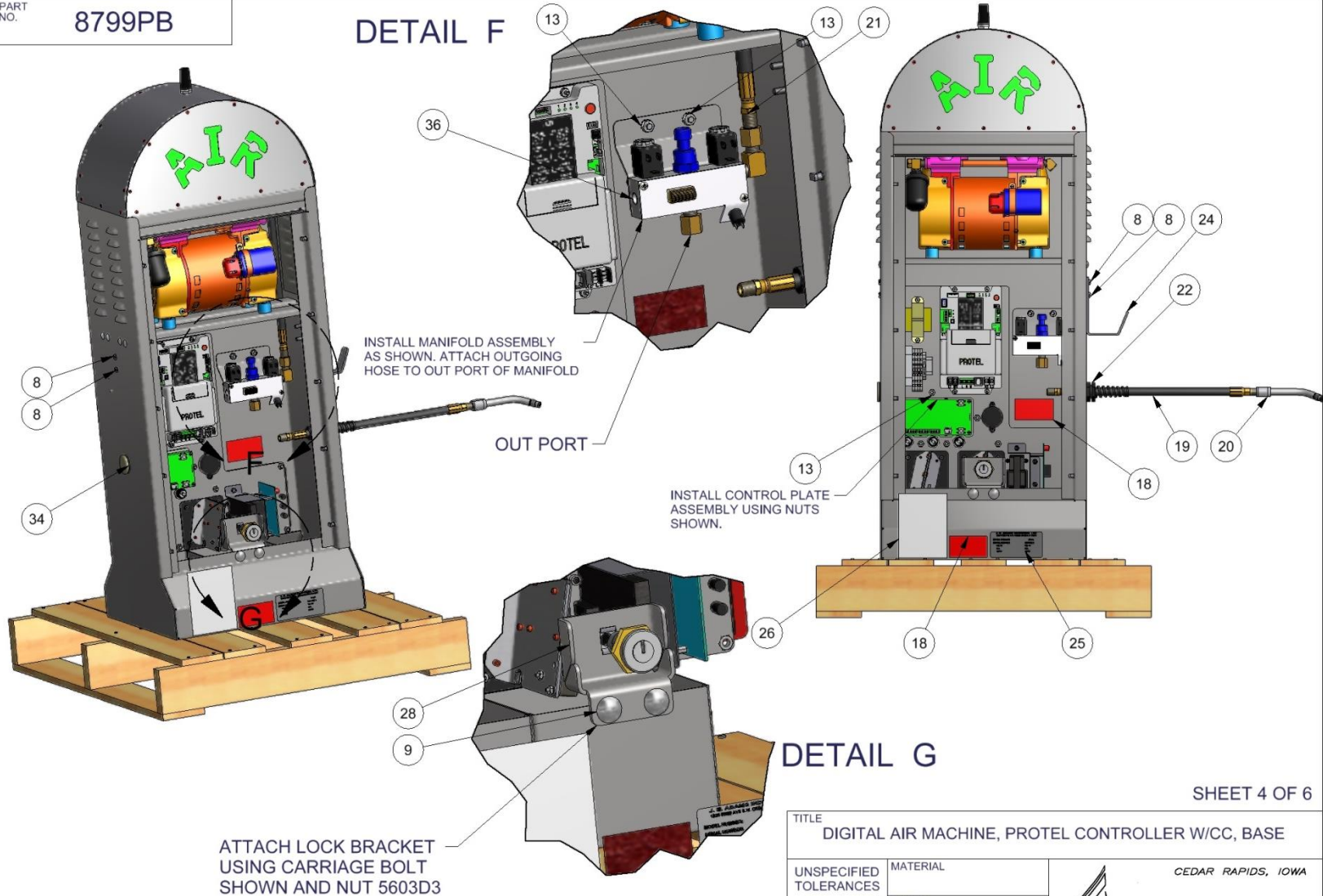

DETAIL G

SHEET 4 OF 6

TITLE		DIGITAL AIR MACHINE, PROTEL CONTROLLER W/CC, BASE	
UNSPECIFIED TOLERANCES		MATERIAL	
SCALE		CEDAR RAPIDS, IOWA	
1 PL ±.030			
2 PL ±.010			
3 PL ±.003			
ANGLE ±1.0°		DRAWN BY	CHAD K.
		DATE	2/2/2015
		PART NO.	8799PB
		REV.	

REV	NO.	DESCRIPTION	DATE	BY
THIS DOCUMENT SHALL NOT BE REPRODUCED NOR SHALL THE INFORMATION THEREIN BE USED BY OR DISCLOSED TO OTHERS EXCEPT AS AUTHORIZED BY J.E. ADAMS INDUSTRIES				

PART NO.

8799PB

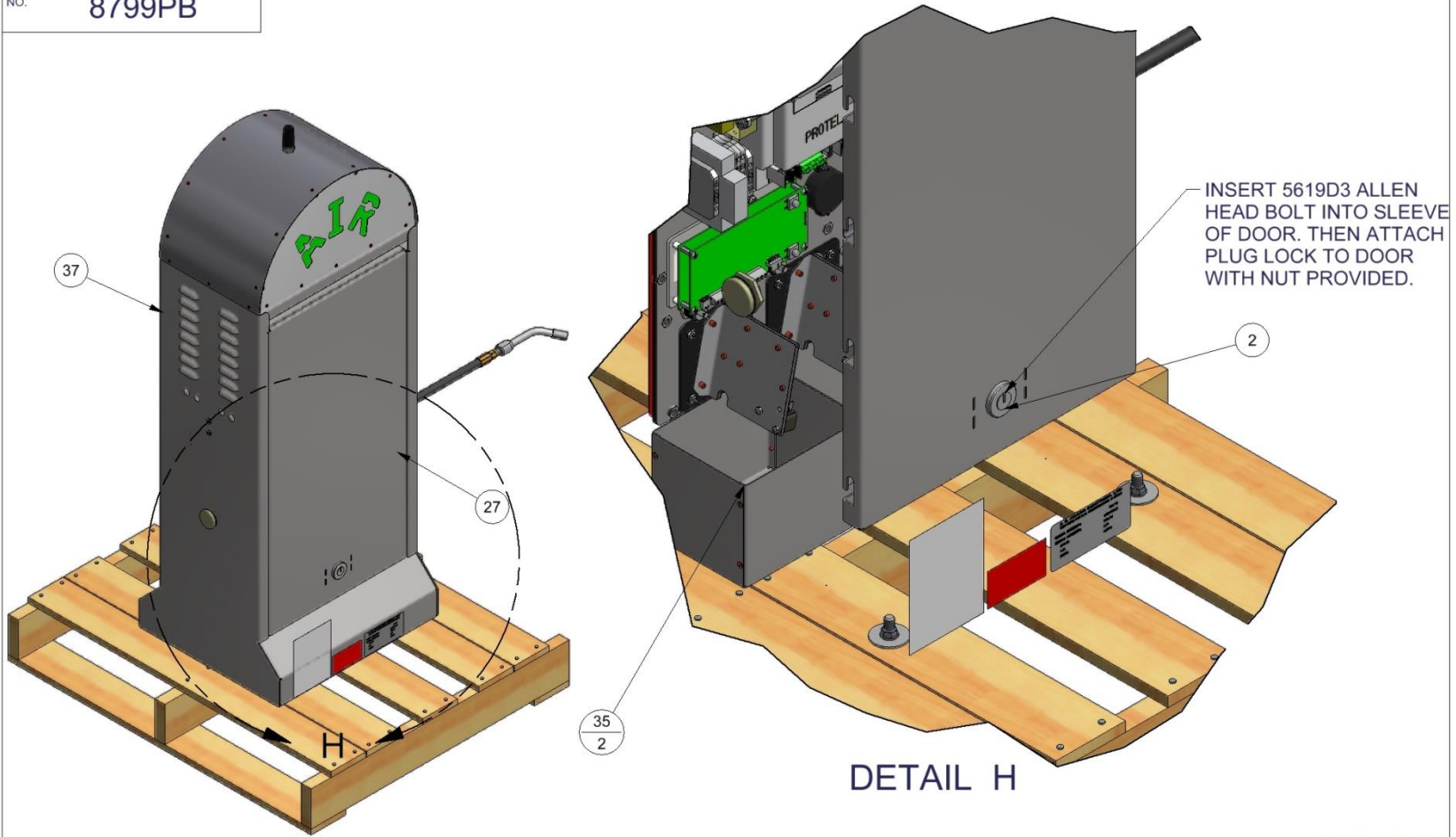

SHEET 5 OF 6

TITLE		DIGITAL AIR MACHINE, PROTEL CONTROLLER W/CC, BASE	
UNSPECIFIED TOLERANCES		MATERIAL	
1 PL ±.030		SCALE	
2 PL ±.010		DRAWN BY CHAD K.	
3 PL ±.003		DATE 2/2/2015	
ANGLE ±1.0°		PART NO. 8799PB	
		CEDAR RAPIDS, IOWA	
		REV.	

REV	NO.	DESCRIPTION	DATE	BY
THIS DOCUMENT SHALL NOT BE REPRODUCED NOR SHALL THE INFORMATION THEREIN BE USED BY OR DISCLOSED TO OTHERS EXCEPT AS AUTHORIZED BY J.E. ADAMS INDUSTRIES				

PART NO.

8799PB

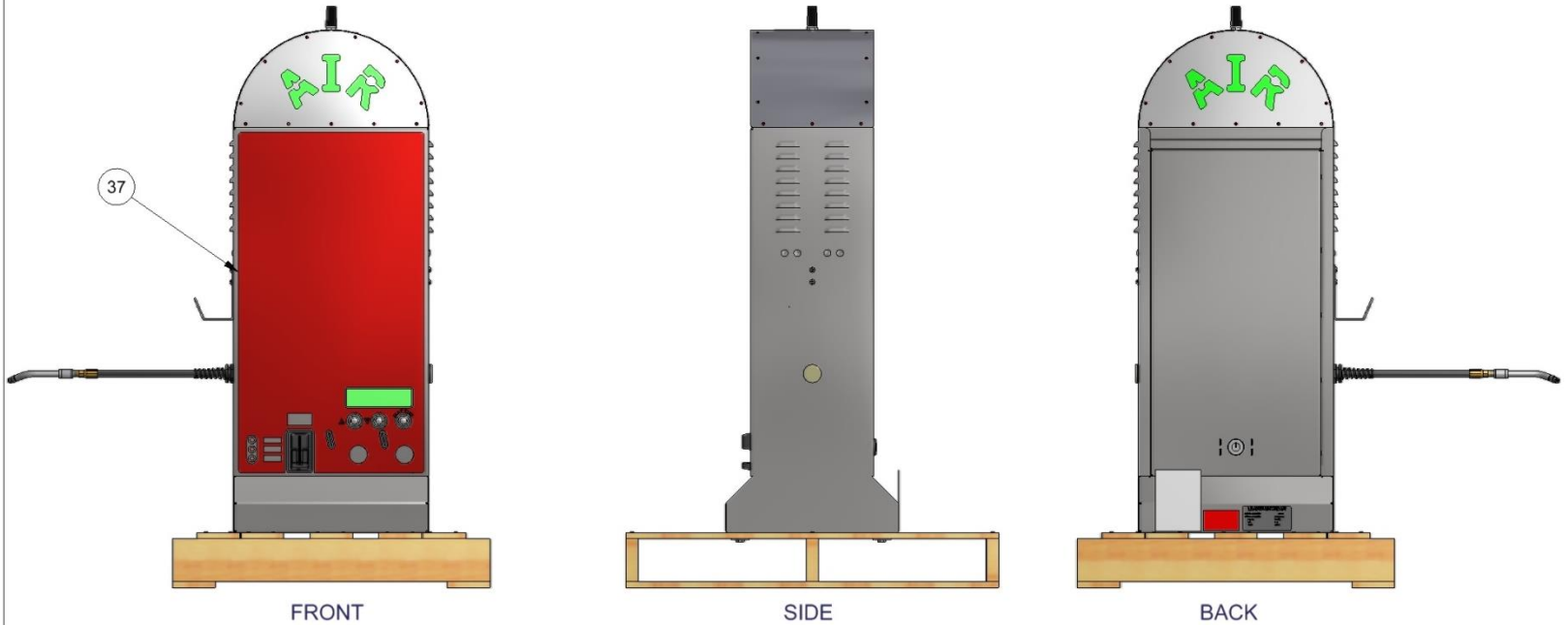

SHEET 6 OF 6

TITLE		DIGITAL AIR MACHINE, PROTEL CONTROLLER W/CC, BASE	
UNSPECIFIED TOLERANCES	MATERIAL	 CEDAR RAPIDS, IOWA	
1 PL ±.030	SCALE		
2 PL ±.010	DRAWN BY	CHAD K.	
3 PL ±.003	DATE	2/2/2015	
ANGLE ±1.0°	PART NO.	8799PB	
			REV.

REV	NO.	DESCRIPTION	DATE	BY
THIS DOCUMENT SHALL NOT BE REPRODUCED NOR SHALL THE INFORMATION THEREIN BE USED BY OR DISCLOSED TO OTHERS EXCEPT AS AUTHORIZED BY J.E. ADAMS INDUSTRIES				

PART NO. **8799-515AW**

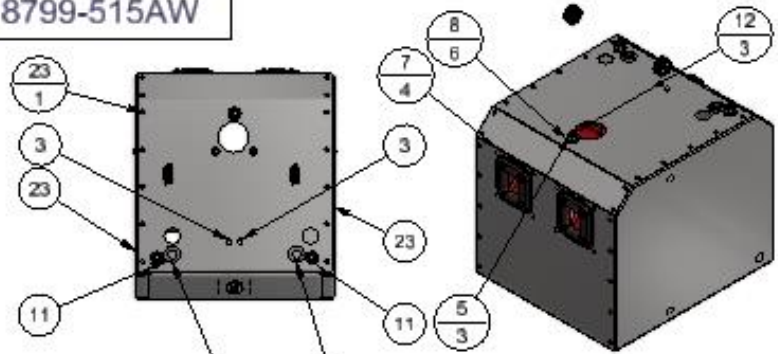

THIS END OF HOSE RUNS THRU THIS GROMMET N ASSEMBLY AFTER ATTACHED TO HOSE REEL.

THIS END OF HOSE RUNS THRU THIS GROMMET N ASSEMBLY AFTER ATTACHED TO HOSE REEL.

PLUG IS ATTACHED TO MAIN MACHINE WHERE THE AIR HOSE IS NORMALLY

PLUG IS ATTACHED TO MAIN MACHINE WHERE THE WATER HOSE IS NORMALLY

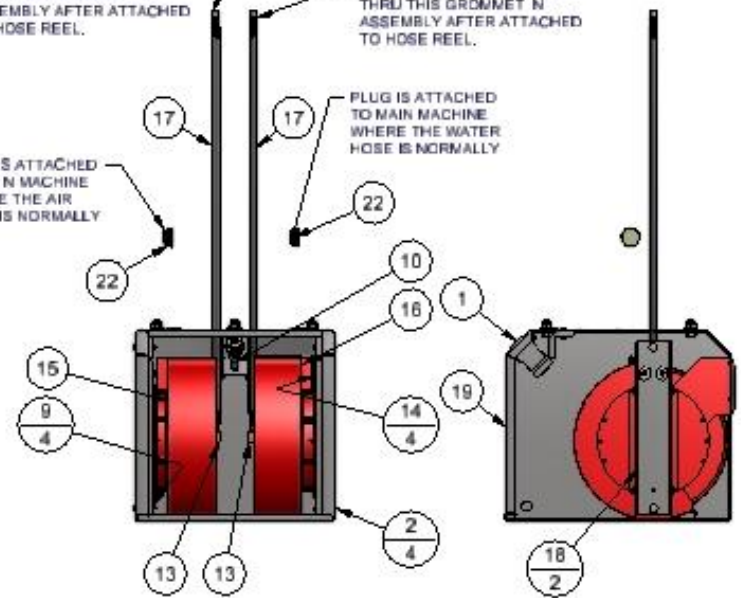

BILL OF MATERIALS

ITEM	PART NUMBER	DESCRIPTION	QTY
1	22001-6A	PLUG LOCK, LARGE, WITH LOCK CORE	1
2	5600D3	5/16-18 x 1.5 CARR BOLT	4
3	5601D4	1/4-20 x 3/4 HHCS-SS	2
4	5603D1	10 Std NC Nylock Nut	4
5	5603D11	1/2 Std NF Nylock Nut	3
6	5603D2	1/4 Std NC Nylock Nut	2
7	5604D1	#10-24 x 1/2 CARR BOLT	4
8	5606D10	WASHER, FLAT 1/2 SAE	6
9	5611D4	NUT, 5/16-18 UNC KEPP- SS	4
10	5619D3	1/2" - 13 HEX SOC HEAD SCREW	1
11	5639D6	RUBBER GROMMET	2
12	5646D3	HHCS, 1/2-13 X 1", SS	3
13	5800D6	90 DEG. NPT STREET ELBOW	2
14	6025-711	1/2-13 x 3/4 HEX HEAD BOLT	4
15	6025-7EXT	REEL CRAFT REEL WITH ROLLERS, LEFT	1
16	6025-8EXT	REEL CRAFT REEL WITH ROLLERS	1
17	8545-48	AIR HOSE ASSY, 1/4" X 48"	2
18	8799-305W	HOSE REEL MOUNT WELDMENT	2
19	8799-518W	HOSE REEL DOOR WELDMENT	1
20	8799-520W	LOCK BRACKET WELDMENT	1
21	8799-521	REEL HOLD DOWN	2
22	8799-6003	PLUG, WATERTIGHT FITTING HP SERIES 2	2
23	8799W-515A	HOSE REEL BOX WELDMENT	1

TITLE HOSE REEL ASSEMBLY, AIR/WATER, 8799 SERIES VAULT			
UNSPECIFIED TOLERANCES 1 PL ±.030 2 PL ±.010 3 PL ±.003 ANGLE ±1.0°	MATERIAL	CEDAR RAPIDS, IOWA	
	SCALE		
	DRAWN BY CHAD K.		
	DATE 2/10/2015	PART NO. 8799-515AW	REV

REV	NO.	DESCRIPTION	DATE	BY
THIS DOCUMENT SHALL NOT BE REPRODUCED NOR SHALL THE INFORMATION THEREIN BE USED BY OR DISCLOSED TO OTHERS EXCEPT AS AUTHORIZED BY J.E. ADAMS INDUSTRIES				

PART NO. 8799 SERIES

THIS DOCUMENT SHALL NOT BE REPRODUCED NOR SHALL THE INFORMATION THEREIN BE USED BY OR DISCLOSED TO OTHERS EXCEPT AS AUTHORIZED BY J.E. ADAMS INDUSTRIES

BILL OF MATERIAL

ITEM NO.	PART NO.	DESCRIPTION	QTY.
----------	----------	-------------	------

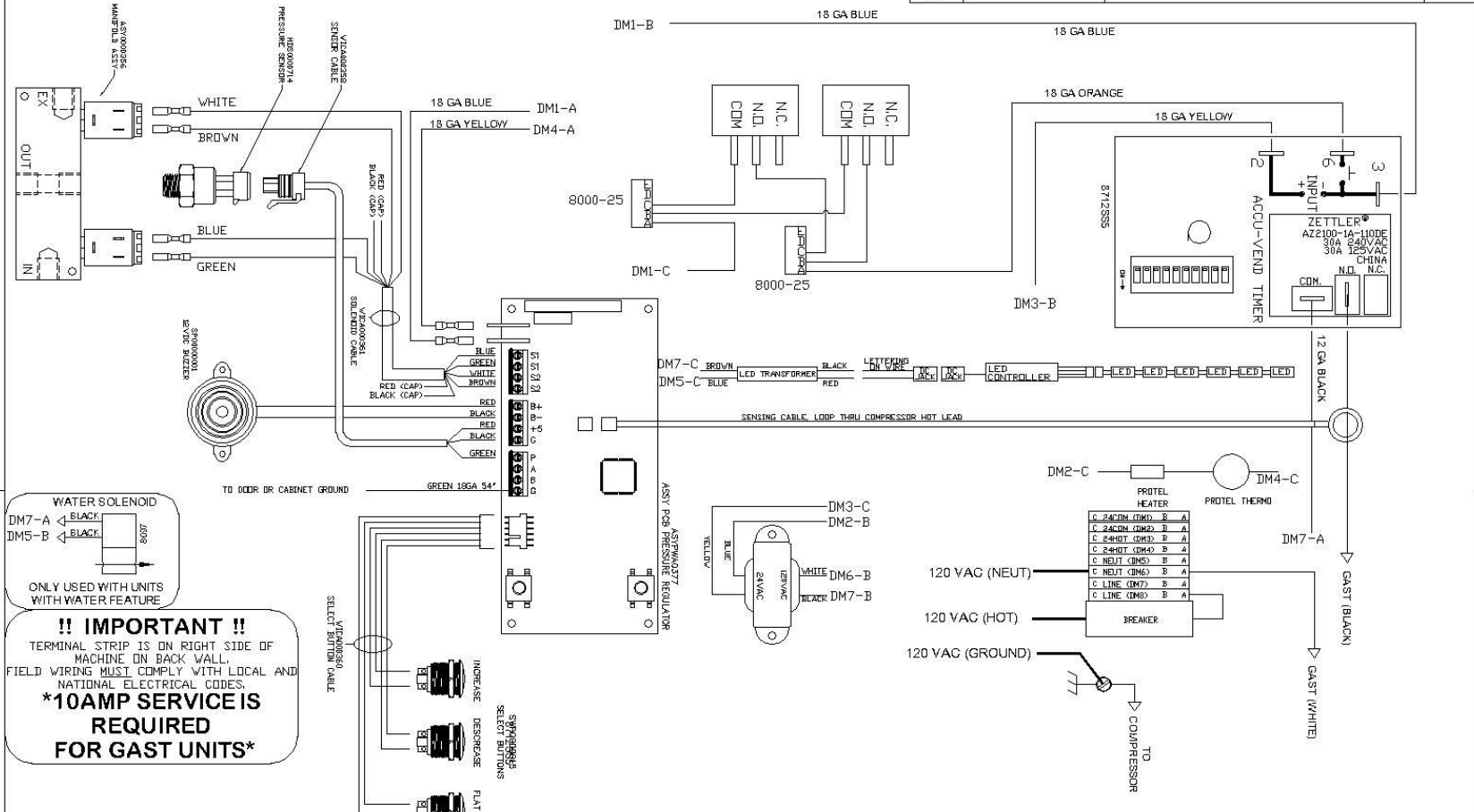

TITLE		8799 DIGI PROTAL SERIES, SSAC,	
SCALE	NONE	CEDAR RAPIDS, IOWA	
UNSPECIFIED TOLERANCES	DRAWN BY CK		
FRACT. ± 1/32	DATE 1-28-15		
2 PL ± .020	REL. FOR PROD.	PART NO. 8799 SERIES	REV. A
3 PL ± .010			
ANGLE ± 1.0°			

REV	NO.	DESCRIPTION	DATE	BY
A	7916	ELECTRICAL SCHEMATIC COMPLETELY UPDATED, SEE ECR12-30-16	CK	

PART NO. **8799 SERIES**

THIS DOCUMENT SHALL NOT BE REPRODUCED NOR SHALL THE INFORMATION THEREIN BE USED BY OR DISCLOSED TO OTHERS EXCEPT AS AUTHORIZED BY J.E. ADAMS INDUSTRIES

BILL OF MATERIAL

ITEM NO.	PART NO.	DESCRIPTION	QTY.
----------	----------	-------------	------

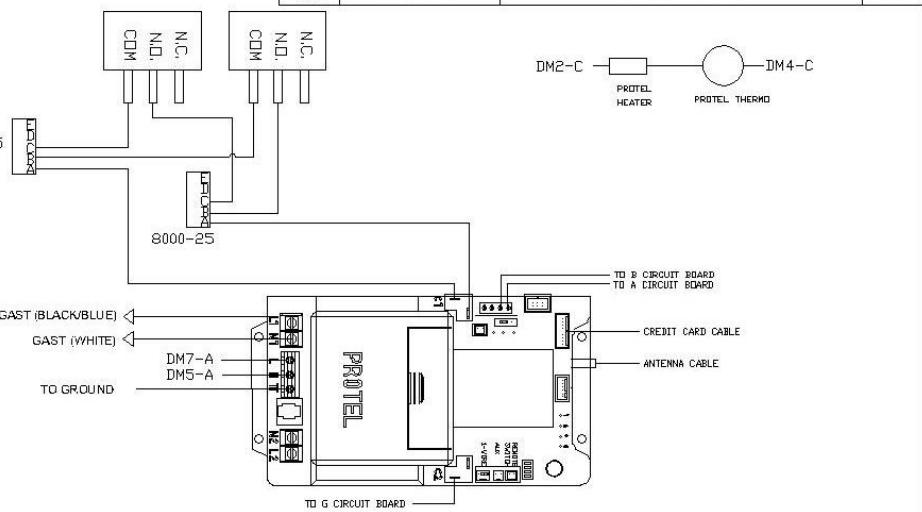
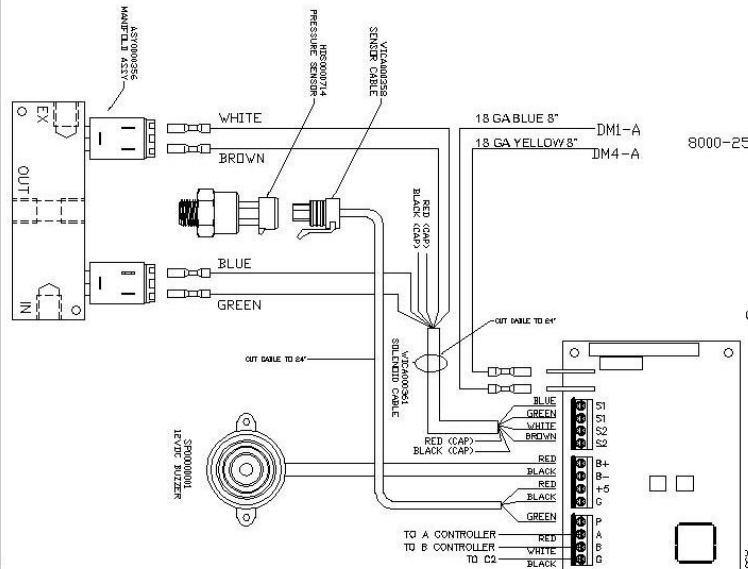

WATER SOLENOID
 TO L1 BLACK
 TO N1 BLACK
 TO E AND FOR OUTSIDE NETWORKS BUILD ONLY USED WITH UNITS WITH WATER FEATURE

!! IMPORTANT !!
 TERMINAL STRIP IS ON RIGHT SIDE OF MACHINE ON BACK WALL.
 FIELD WIRING MUST COMPLY WITH LOCAL AND NATIONAL ELECTRICAL CODES.
10AMP SERVICE IS REQUIRED FOR GAST UNITS

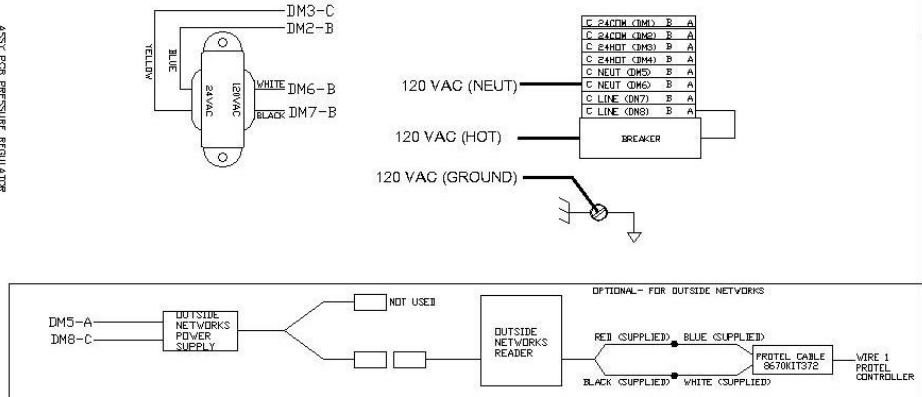
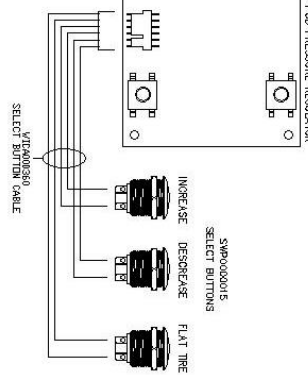

TITLE
8799 DIGI PROTEL SERIES, PROTEL CONTROLLER

SCALE	NONE		CEDAR RAPIDS, IOWA
UNSPECIFIED TOLERANCES	FRACT. ±1/32 2 PL ±.020 3 PL ±.010 ANGLE ±1.0°		
DRAWN BY	CK	PART NO. 8799 SERIES	REV. B
DATE	1-28-15		
REL. FOR PROD.			

REV	NO.	DESCRIPTION	DATE	BY
B	7916	UPDATED DUE TO ADD OF ADDITIONAL TERMINAL	1-3-16	CK
A	7804	ADDED INFO FOR OUTSIDE NETWORKS INSTALL	8-5-16	CK